

Black Knight



12th Annual Intelligent Ground Vehicle Competition
Oakland University, Rochester, Michigan
June 12th – 14th 2004

Faculty Statement:

I certify that the work done by all students on this project is consistent with a senior design course and that the vehicle has been significantly modified for this year's competition.

Dr. Fernando Gonzalez
fgonzale@pegasus.cc.ucf.edu

Introduction

The University of Central Florida's Robotics Laboratory is pleased to enter Black Knight in the 2004 Intelligent Ground Vehicle Competition. It is an autonomous vehicle designed to excel at this competition. Based on a Pride Mobility scooter, Black Knight uses four cameras to gather information about the world around it. An advanced path-planning algorithm is used for navigation on a map created from sensor input. An optical sensor, an electronic compass, DGPS, and two magnetic encoders supply speed and position information to Black Knight. Data from all of these sensors allow Black Knight to avoid obstacles and navigate through varied terrain. Black Knight is designed to perform in all challenges of the 2004 Intelligent Ground Vehicle Competition. This design paper will highlight Black Knight's electronic, mechanical, computer and software systems. It will also include information on the design process, team and vehicle organization.

The Design Life Cycle Model

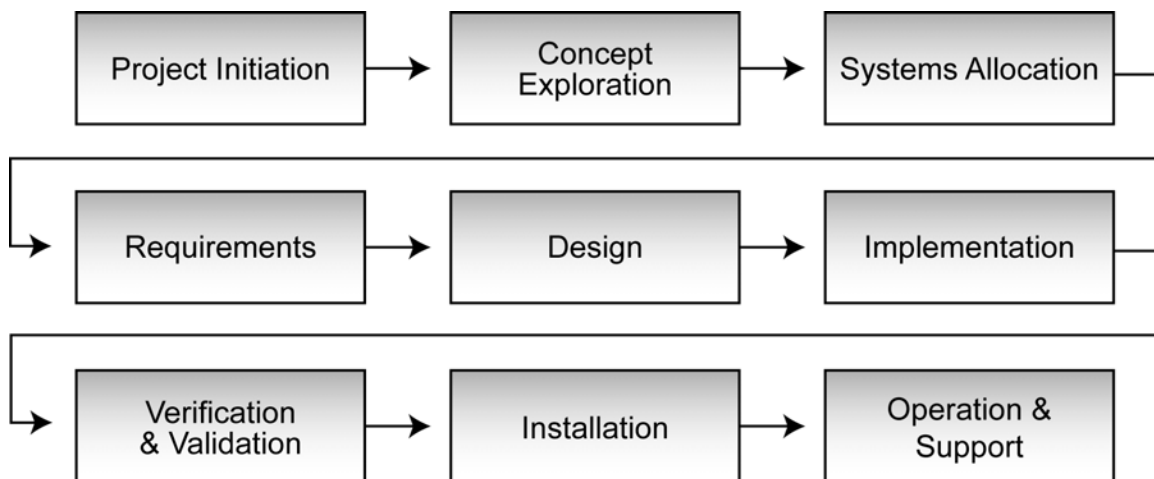

Figure 1 – Design Life Cycle Model

To meet the requirements of the Intelligent Ground Vehicle Competition, a design processes was chosen and followed. The Design Life Cycle Model, as stated by Bernd Bruegge and Allen H. Dutoit, 2000, was selected for its thoroughness. Following this process, needs are identified and fulfilled. It also

allows for unforeseen requirements and additional testing. The first stages of the design cycle, Figure 1, cover identification of needs for the system. The project was initiated, as was the exploration of concepts for optimal performance. Resources for systems were allocated and requirements were identified. The design was then closely investigated. The competition was reviewed and specifications were identified to meet the challenges. Once the challenges were reviewed and identified, development began. Next, the design was implemented and finalized through constant verification and evaluation. Simulation and real world testing were used to evaluate Black Knight's performance. This ensured that it met its goals and requirements. Testing and support continue as the product is fine-tuned.

Team Organization

Team Black Knight is a multi-disciplinary team made up of computer science, electrical and computer engineering students. The team is organized as follows:

NAME:	RESPONSIBILITY:	CLASS STANDING:
Tim Roberts	Team Captain, Electrical Systems, Chassis	Graduate Student, EE
Richard Andres	Electrical Systems, Chassis	Undergraduate, EE
Daniel Barber	Vision System, World Map, Communication	Undergraduate, CpE
Brian Becker	Vision System	Undergraduate, CpE
Victor Boyer	Vision System	Undergraduate, EET
Brian Oigarden	Steering and Speed Systems	Undergraduate, CpE
Brent Sislack	Path Planning (Autonomous Challenge)	Undergraduate, CS
Gary Stein	Path Planning (Navigation Challenge), DGPS, Chassis	Graduate Student, CpE

This chart shows each student's primary focus, although team members were encouraged to be involved in all aspects of Black Knight.

Steering

For proper control of Black Knight's movement it is important to know the angle of the front steering wheels. An array of optical detectors and an alternating black and white code wheel were mounted along the steering column, making it possible to accurately measure steering angle. A resolution of 0.39° was obtained. A PIC microcontroller combines the output of the detectors to form an 8-bit data string, which is sent to the steering control circuit. The steering sensor provides error feedback for compensation of steering angle.

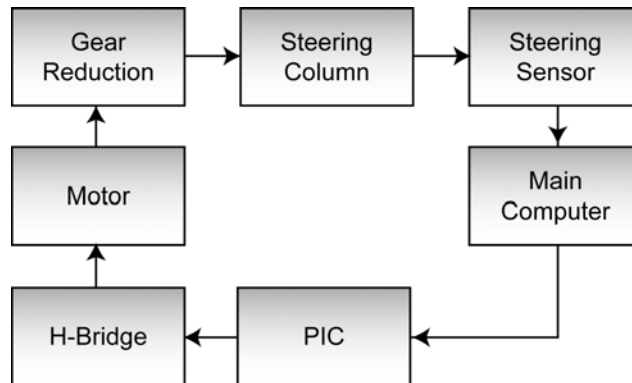

Figure 2 – Steering System

The main computer sends a desired angle to the steering control circuit. This desired angle is based on a comparison of the current heading of the vehicle to its desired heading. A PIC microcontroller compares the current angle of the steering wheels to the desired angle sent by the main computer. The steering microcontroller adjusts the steering angle using pulse width modulation and an H-bridge to drive the steering motor.

Speed

The main computer calculates the desired speed of Black Knight and sends it to the speed control circuit. A PIC microcontroller processes this data and sends a value to a D/A converter. The D/A converter feeds a voltage to the scooter's original speed controller. This speed controller then adjusts the power

sent to the drive motor. The microcontroller gathers data from two encoders, one on each of the rear wheels. The actual speed of the vehicle is calculated based on this input and sent to the main computer.

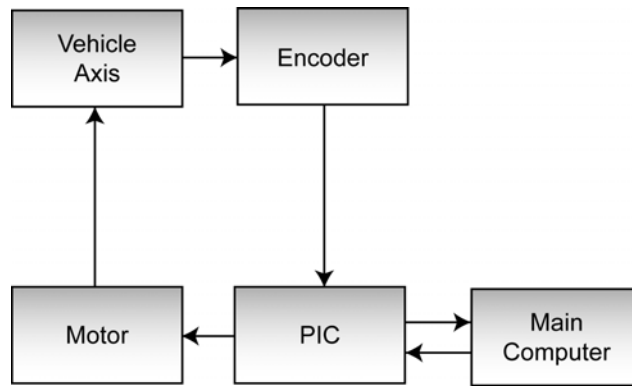

Figure 3 – Speed System

The main computer uses this data to adjust the error feedback for speed compensation. The power to the motor is adjusted incrementally to smooth the transition to the desired speed. When the vehicle is on an incline, power is increased or decreased as needed to compensate for the slope of the terrain.

Emergency Stop

The emergency stop system used by Black Knight is a relay which interrupts the control line to the embedded speed controller. When the manual or wireless buttons are pushed, power to the speed motor is set to zero stopping the vehicle. This hardware implementation allows the vehicle to stop under any error condition, and a software failure cannot affect e-stop capability. A button on the side of the vehicle allows easy reset of the emergency stop system making the vehicle ready to move again. In the event the vehicle is stopped on a slope, it will not roll forward or backwards. The emergency stop system has been tested and the stopping distance is less than two feet after e-stop is activated.

Electrical System

Black Knight's microcontroller systems are mounted in a drawer for easy access. This drawer houses the steering, speed and e-stop circuits, and acts as a hub for all the DC circuits on the vehicle. All wires attach to the drawer with connectors, and branch out from there to the individual circuits inside. This allows quick removal for repair and simplifies signal and power distribution. Two switches and three buttons are on the front of the drawer. The switches control 12V and 24V power allowing the drive system to be turned off for safety while troubleshooting other systems. The reset buttons allow the steering, speed, and e-stop circuits to be individually reset.

Power

Black Knight is an electrically powered vehicle. It uses two deep cycle batteries in series providing 24V to power the speed and steering motors. The vehicle uses two additional 12V, 55Ah batteries. The first of these powers the on-board computers through a 1200W inverter, while the second powers the compass, DGPS, and microcontroller circuits via a 5V regulator. Individual fuses are used to protect the 24V and 12V electrical systems. All of the electrical systems share a common ground connection. The computers run for two hours on a full charge. The remaining electrical systems have a battery life of up to ten hours. This gives Black Knight an overall run time of 2 hours of continuous use, which can easily be extended by switching one battery.

Chassis

Black Knight is based on a Pride-Mobility Scooter. The original vehicle was stripped down to the frame and drive system. Additional framework was constructed to support computers and sensors and attached to the existing frame. The original steering column was retained and a motor added which changes steering angle via a chain and gears. A switch is depressed when the

steering is at the safe limit of its travel. When this switch is depressed, power to the steering motor is reduced to safeguard motor and linkage. Black Knight's body is a two-piece fiberglass shell. It provides protection from the elements while allowing easy access to the computers and sensors. A monitor is mounted at the back of the vehicle so computer output can be viewed at the same time as corresponding vehicle movements.

Computers

1. Dell Precision 530 Workstation

- Specifications
 - Dual 1.7 GHz Xeon Pentium III Processors
 - 1 Gigabyte RAM
 - Windows XP
- Responsibilities
 - Vision Processing
 - World Map and Terrain Creation
 - Notify Path Planning of World Map Changes

2. Dell Precision 340 Workstation

- Specifications
 - 2 GHz Pentium IV Processor
 - 512 Megabytes RAM
 - Linux 2.4.20 Kernel
- Responsibilities
 - Path Planning
 - GPS Filtering
 - Supplying GPS and Compass data to Vision Computer
 - Error Correction

Sensors

1. Ashtec BR2G Differential GPS

- Specifications
 - Accuracy - Better than 1.0 meter, horizontal RMS
 - Reacquisition Time - 2 seconds (typical)
 - Update rate - Up to 10 position reports per second
- Purpose
 - Provide accurate location of vehicle to the main computer in latitude and longitude
 - Accuracy allows targets to be located well within the 2 meter requirement

2. TCM2-50 Digital Compass

- Specifications
 - Heading Accuracy
 - When level - 1.0° RMS
 - When tilted - 1.5° RMS
 - Heading Resolution - 0.1°
 - Tilt Accuracy - $\pm 0.4^\circ$
 - Tilt Resolution - 0.3°
- Purpose
 - Provide accurate heading of vehicle to main computer
 - Accuracy allows the vehicle to navigate through obstacles within the guidelines of the challenges

3. MDFKG2101 Magnetic Encoder

- Specifications
 - Pulse/Revolution - 256 pulses ring magnet 16 pole-pairs
 - Measuring Steps - 1024
- Purpose
 - Sense wheel rotation and relay information to speed control circuit

4. Quickcam Pro 4000 Web Cam

- Specifications
 - Video Capture Resolution - 640 x 480
 - Still Image Resolution - 1280 x 960
- Purpose
 - Provide image capture for vision system

5. Photoreflector Array

- Specifications
 - 6 Photo IC's with open collector output

- Microcontroller for data fusion and serial conversion
- Purpose
 - Sense angle of steering system and relay data to steering control circuit

Vision

Black Knight uses computer vision as its main source for obstacle detection. By processing the images from four cameras, it is possible to build a map of the vehicle's surroundings. The cameras are placed so Black Knight can detect obstacles regardless of direction of movement. This helps in preventing collisions when turning and backing up. All four cameras are used concurrently to create an accurate model of its environment.

To assist in object identification in captured images, several image-processing techniques are used. Using image-filtering techniques the maximum amount of data can be retrieved from each image. The image filters used create hue, saturation, intensity, edge, and binary data from the original picture. Filters clean up the image, removing noise and enhancing visual features of objects in frame by adjusting brightness and contrast levels. In addition to using image filters, the image is segmented so that ten visual characteristics can be extracted from the filtered image data. These ten visual characteristics are used for identification of all objects and include average red, green, blue, texture, intensity, hue, saturation, and binary color data. Tinted neutral density filters have been placed on camera lenses to compensate for outdoor lighting conditions. These hardware filters improve the analog input to the vision system.

After an image has been processed and visual characteristics are extracted, a three-layer back propagation neural network is used for identification. This network uses all ten of the extracted visual characteristics to categorize image segments, thereby identifying obstacles and lines. Since image data is usually unreliable due to differing lighting conditions and noise, a neural network is ideal for processing and identification. Since a neural network

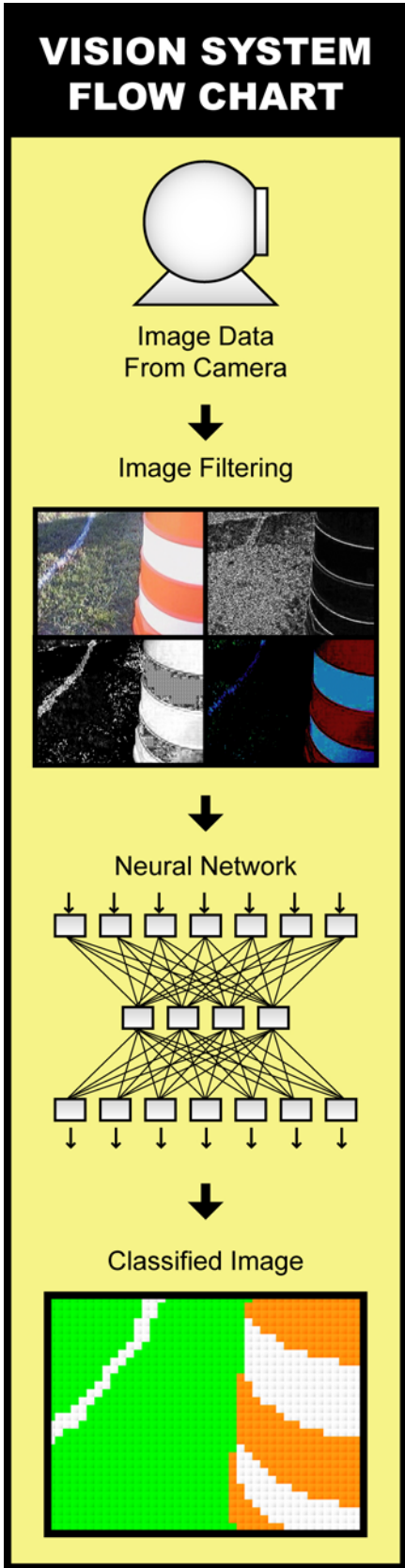

works quickly, independently of what type of information is passed into it, it is perfect for real time processing of image data. A training program is used to assist in the training of Black Knight's neural network. This program is able to adjust learning rates and fine-tune the neural network for correct identification of objects. This interactive program lets the user tell the neural network what the correct output should be, thereby training the network. It also allows the neural network to attempt identification of objects in the image for instant feedback on training. With its properly trained neural network, Black Knight can successfully identify objects under any conditions.

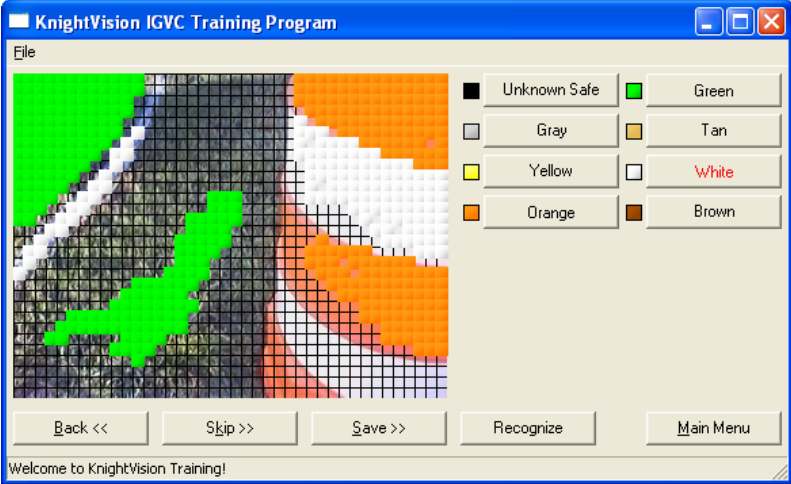

Figure 4 – Vision Training Program

With four cameras running simultaneously, it is necessary to have extra computing power for real time processing. A dedicated computer is used for image classification. This computer processes all vision information from the cameras in addition to building and maintaining a world map. This extra computing power allows the processing of 15 frames per second per camera.

World Map

In order to navigate through its surroundings Black Knight creates a world map. In addition to processing images, the vision computer builds this map using information from classified images. The map contains all obstacles the vehicle has encountered during its run. The on-board monitor displays the map so users can see what Black Knight has detected and where it has traveled. This capability is extremely useful both for testing purposes and terrain mapping. The world map program locates its map to real world coordinates using DGPS and compass data. This data is also used to calculate the vehicles position in the world map. As the world map is altered, the vision computer sends the changes to the path-planning computer for navigation. Exporting this stored world map would be an easy addition to the functionality of the program.

Path Planning

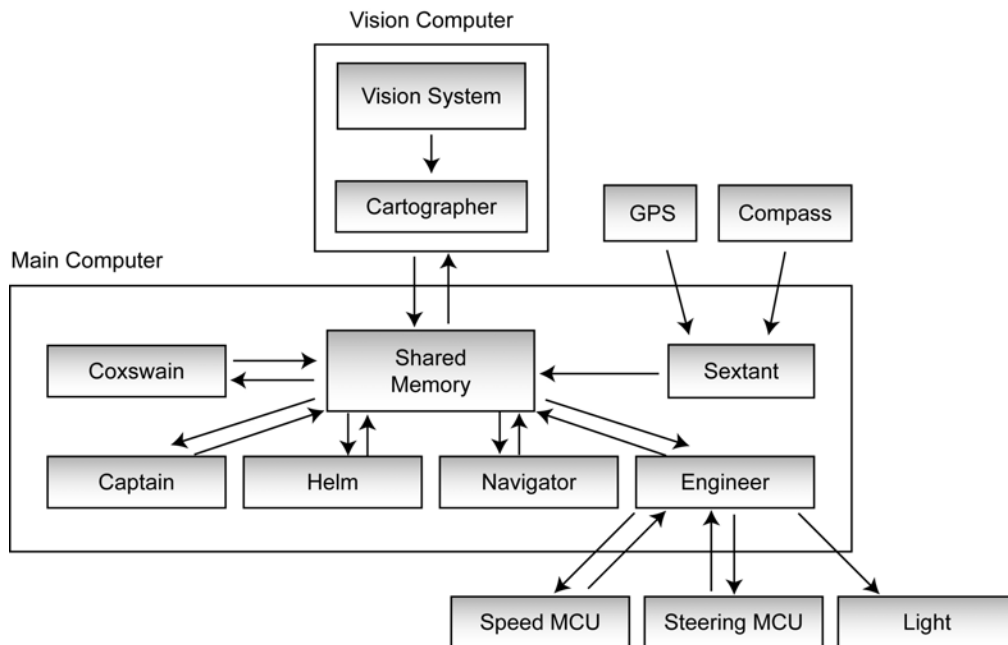

Figure 5 – System Layout

The main computer receives sensor data from the Vision Computer, DGPS, compass, photoreflector array and encoders. World map data received from the Vision Computer is added to shared-memory on the main computer. Raw data from the DGPS and compass is placed in shared memory by the Sextant program. Since this information is not formatted and may have errors, a program called Coxswain was developed. Coxswain uses a ded-reckoning system to calculate vehicle location independent of DGPS and compass data. It filters the raw DGPS data using an Extended Kalman Filter. Filtered DGPS data and ded-reckoning position are average. This information is used to update vehicle location in shared memory. This helps minimize drift in vehicle position. The information is also sent back to the Vision Computer for updating the world map.

The Navigator program uses the world map from shared memory to plot a path. Depending on the type of task at hand (navigation or autonomous challenge) different path finding algorithms are used. Once a path has been found it is sent to shared memory for other control programs to use. The Captain program determines what information should be used by the other control programs. It tells the Helm program what actions to take based on information supplied by Navigator. The purpose of Helm is to realize the theoretical path by adjusting the vehicle's desired angle and speed. Helm information is formatted by the Engineer program for the steering and speed microcontrollers. If an obstacle is detected, the Engineer activates the red light on top of the vehicle. All feedback from the steering and speed microcontrollers is placed in shared memory by Engineer. Helm processes this feedback and acts to ensure the planned path is accurately followed.

Navigation Challenge

During the Navigation Challenge the vehicle will have to find its way to given way points relying on its sensors. The main computer will use a cellular decomposition method to navigate from waypoint to waypoint. The waypoints

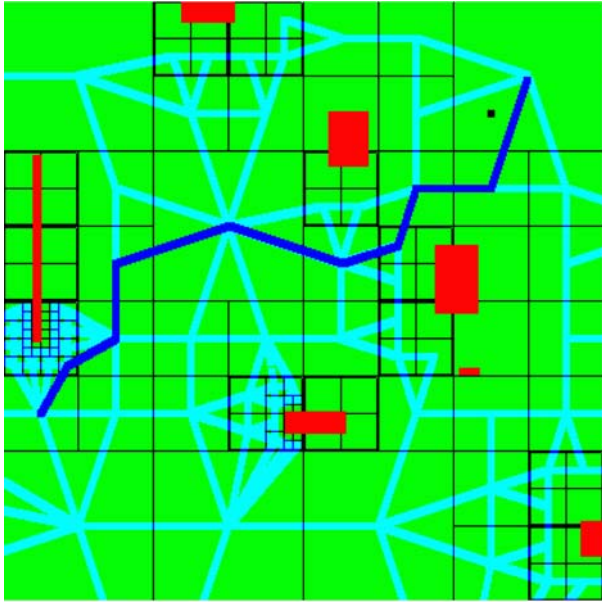

Figure 6 - Navigation Challenge

are given in latitude and longitude. The main computer orders them using a Traveling Salesman algorithm. With the accuracy of both the DGPS and compass, along with the filtering algorithms, the vehicle is expected to arrive at the waypoints. Extensive testing has shown that the vehicle will arrive within a 1-meter radius of waypoints. The vision system will use a separate classification system for this

challenge. The system will only be trained on green grass and given obstacles. The speed of the vehicle will be set to allow movement to the waypoints in the given time while still receiving accurate information from the sensors. The vehicle has been rigorously tested in simulation. A simulation program tests the vehicle's path planning method. Various scenarios were successfully simulated and tested in the real world.

Autonomous Challenge

During the autonomous challenge the vehicle has to detect and avoid obstacles while staying within two white or yellow lines which delineate a course. The vision system will use a full classification method to identify all obstacles and colored lines. The path-planning algorithm used for this challenge is the Potential Fields method. This

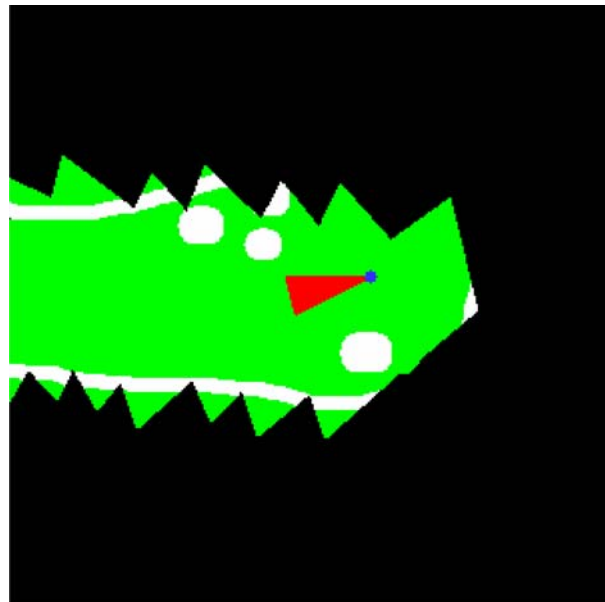

Figure 7 - Autonomous Challenge

method works by translating the world map. It takes each obstacle and places it in the translated map as a weighted point. Points of decreasing weight are placed around the obstacle, with distance from the obstacle inversely proportional to weight. When the map has been translated, the program determines the next point to travel to. Points are selected by finding the path that is closest to the desired heading with minimum weight. Path information is sent to Captain. Then an idle state is entered until a new path is required. The vehicle can reverse when faced with dead ends and traps. It retreats to the last safe point and recalculates path. When faced with dashed or solid lines, the vehicle uses a Gaussian blur to fill in gaps. A simulator was designed to test these functions of the vehicle. After the vehicle proved itself in simulation, it was successfully tested on a mock course. This course contained all features of the autonomous challenge.

Budget

Description:	Vendor:	Quantity:	Unit Price:	Total Price:
Overall:				
Dell workstations, display, CD-RW, etc.	Dell	1	\$5,339.12	\$5,339.12
KVM and serial PCI	Dell	1	\$100.00	\$100.00
Celebrity XL 4 wheel scooter	Pride mobility	1	\$1,100.00	\$1,100.00
Electronics/Sensors:				
SC34 DA Optima Yellow Top deep cycle	Insight/Autozone	6	\$150.00	\$900.00
Ashtec BR2G DGPS	Thales Navigation	1	\$1,000.00	\$1,000.00
Electrical Components	Digi-Key	1	\$440.00	\$440.00
Mobile Power Inverter	Mobile Power	1	\$200.00	\$200.00
MDFKG2101 Magnetic Encoder	Baumer Electronics	2	\$35.00	\$70.00
TCM2-50 Digital Compass	PNI Corporation	1	\$800.00	\$800.00
Electrical Components	Skycraft Components	1	\$100.00	\$100.00
Vision:				
Quickcam Pro 4000	Logitech	4	\$90.00	\$360.00
USB expansion card	Belkin	1	\$30.00	\$30.00
Chassis:				
Bodine Electric Motor	Power and Pumps Inc.	1	\$469.00	\$469.00
Sprockets and Chain	Miller Bearing	1	\$150.09	\$150.09
Fiberglass Body Fabrication	Maiden Marine	1	\$780.00	\$780.00
			TOTAL:	\$11,838.21

Sponsors

U.S. Army Research Development and Engineering Command
Simulation and Training Technology Center
RDECOM, STTC
 12423 Research Parkway
 Orlando FL 32826

Institute for Simulation and Training
IST
 3280 Progress Drive
 Orlando FL 32826