

Bearcat Cub Robot

Design Report

**The 12th Annual Intelligent Ground Vehicle Competition
At Oakland University in Rochester, Michigan; June 12-14, 2004**

Submitted by:

UC Robot Team
Center for Robotics Research
University of Cincinnati
Cincinnati, OH 45221-0072
www.robotics.uc.edu

1. Introduction

The University of Cincinnati robot team has designed and constructed a new robot, the Bearcat Cub, specifically for the IGVC contest, and many other potential applications. The Bearcat Cub is an intelligent, autonomous ground vehicle that provides a test bed system for conducting research on mobile vehicles, sensor systems and intelligent control. The purpose of this report is to describe the conceptual design of the vehicle and its components and highlight the unique innovative aspects of the design and design process.

The report is organized as follows. Section 2 describes the design process and team organization. Section 3 describes the innovations in the design of the mechanical system, which includes the frame, motor, gearbox and wheels. Section 4 describes the innovative aspects of the various electrical systems of the robot including the vision systems for line following, stereo vision for obstacle avoidance and motion control electronics. Section 5 describes the software and systems integration that controls the functions of the robot. Section 6 describes system integration. Section 7 describes the safety and reliability issues. Section 8 describes the performance testing and costs. A bill of materials is given in the appendix.

2. Design Process and Team Organization

The design of the Bearcat Cub involved a sequence of steps and processes as shown in Figure 1. By adhering to the design process, a reliable, robust and efficient robot has been developed.

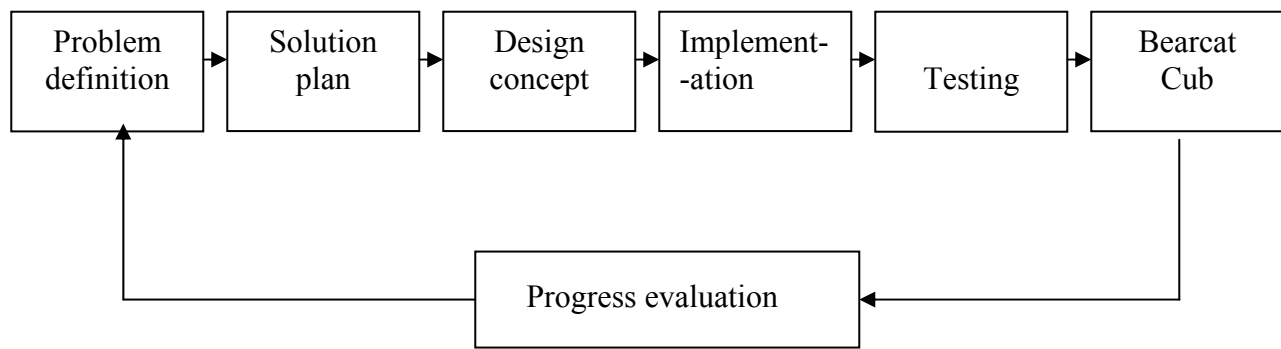

Figure 1. Design process for the Bearcat Cub

Problem definition, for this project, consisted of the study of the contest rules, conditions, and requirements. The contest is held outdoors over an eight-hour day, rain or shine. Sufficient power is needed to run the entire day. The contest also requires that the robot be a certain size and capable of performing certain tasks, such as line following with obstacle avoidance, navigation using a Global Positioning System (GPS) with way point commands, sometimes following a leader vehicle, and always performing safely. The various systems of the robot have been designed based on the different requirements of the competition.

A “divide and conquer” approach has been used that involved breaking the tasks into separate sub tasks. The major systems are classified as mechanical, electrical and computer systems. The design teams for the Bearcat Cub have also been divided according to the functions required such as hardware and software. Each team member has worked on one area of specialization and also learned to operate the entire system. Communication among members has been facilitated by means of group e-mails and weekly meetings. Figure 2 shows the team organization.

Fund raising and decision making has been done with the help of a much larger group using the “wolf pack” or “coalition” strategy. That is, industrial sponsors, alumni team members, faculty, graduate and undergraduate students all support the UC Robot Team and often made significant financial or informative contributions to the team. The Bearcat Cub design was started by a senior design team in 2002.²

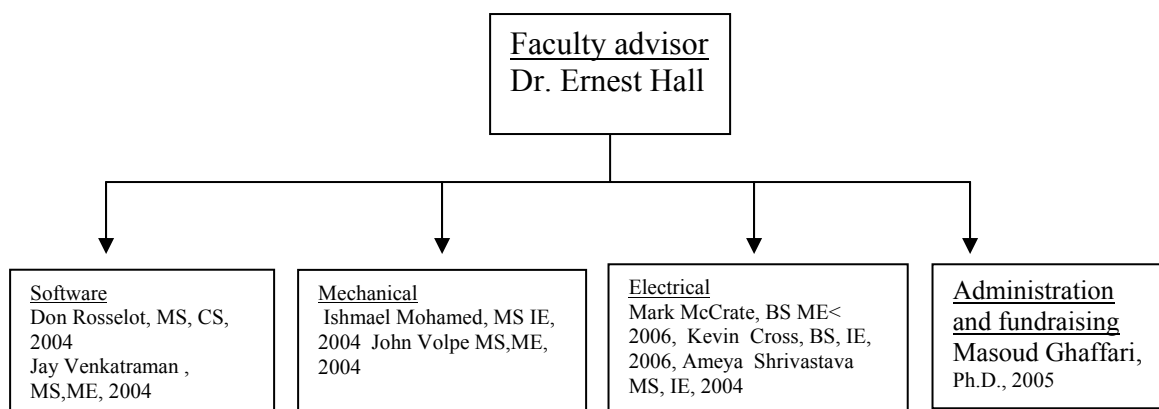

Figure 2. Design team organization.

2.1 Design Concept

The engineering specifications required the robot to have a minimum length of 3 feet and a maximum length of 9 feet. The width should not exceed 5 feet while the height should not exceed 6 feet. The rules require that the robot must be propelled by direct mechanical contact with the ground and wheels have been used for this purpose. Also, the vehicle power supply, the generator sets, falls under the category of combustible fuel which is permissible for the contest. The requirements for the robot have been broken down into individual parts and then the parts which meet these requirements have been selected.

2.2 Innovations in the Design

Several innovations have been made in the Bearcat Cub design.

- The robot is powered by a hybrid power supply consisting of a Honda, super quiet motor generator EU-2000i.
- The frame is made of extruded aluminum that can be constructed easily.
- A laptop provides a modern operating system for ease of software development.
- A web based Galil motion controller provides multi-axis motion control.
- Small but powerful brushless servo motors, Pacific Scientific's PMA43R-00112-00 motors and Copley Controls XSL-230-36 servo amplifier, provide precision steering.
- Sufficient power and speed provided by the highly efficient Segway 25:1 gearboxes and the enhanced traction wheels.
- Two digital cameras and an image tracking system are used for vision sensing.
- A Garmin GPS is used for waypoint navigation.
- A Point Grey Bumblebee stereo vision system is used for obstacle detection.
- A Futaba remote control as well as a standard red button E-stop is used.

3. The Mechanical System

The mechanical system of the robot includes the external frame of the robot, the way it has been constructed with consideration for strength and durability.

3.1 Robot frame

The frame is made of 80/20 aluminum extrusions to have a light weight structure without compromising on the strength. The attachments are made with small joining strips at the

ends or by using corner brackets which sit inside the joints. The advantage of using these is that the frame can be easily reshaped if new components are to be added. Stress and weight calculations for the joints were carried out using a factor of safety of 125%. A drawing of the basic structure is shown in Figure 3.

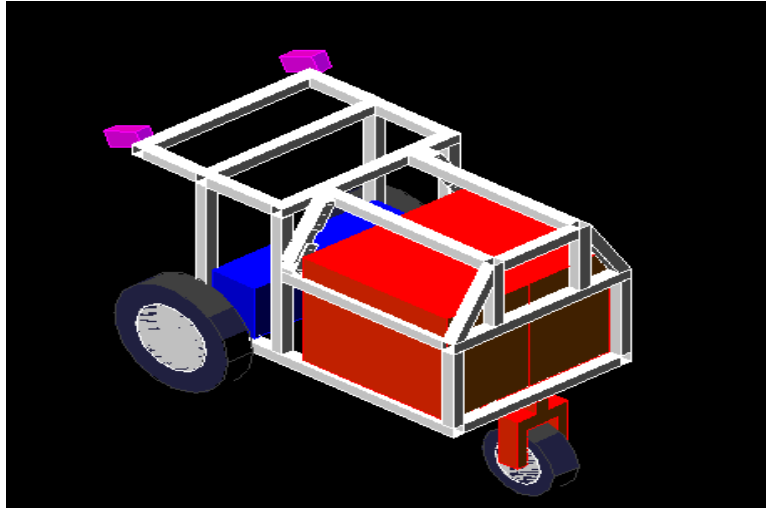

Figure 3. Basic robot structure

3.2 Wheels, motor and gearbox

There are two kinds of wheels on the cub. The main drive wheels are 19" diameter enhanced traction wheels designed by Michelin for Segway's human transporter. The other wheel is a castor wheel which helps improve the navigation capabilities of the robot by providing a zero turning radius. This 8", 90 series, dual castor wheel, is from Borne & Co. With the wheel size being 19" and the maximum speed of the robot 5 miles/hour, a frictional coefficient of 0.125 and a gearbox efficiency of 70% have been used to calculate the required gear ratio. The final design decision was to have a gearbox with a gear ratio of 25:1. The required motor power has been found to be 1.355 hp per motor. Two of Pacific Scientifics' PMA43R-00112-00 2 hp brushless servomotors have been selected for providing power.

The gearbox and the motors have been selected based on calculated values. The robot's power system has been decided as being a generator set and 2 Honda EU-2000i, super quiet sets, as shown in Figure 5 have been chosen for this purpose. The advantage of having a generator set in place of batteries is that the power supply is not interrupted for a long time since refueling the generator set is much quicker than recharging.



Figure 4. Super quiet Honda generator set

4. Electrical and Electronic Systems

The electrical systems of the robot include the motion controller, the cameras, the stereo vision, the GPS, and the emergency E-stop system. The functional block diagram of the design is shown in Figure 5.

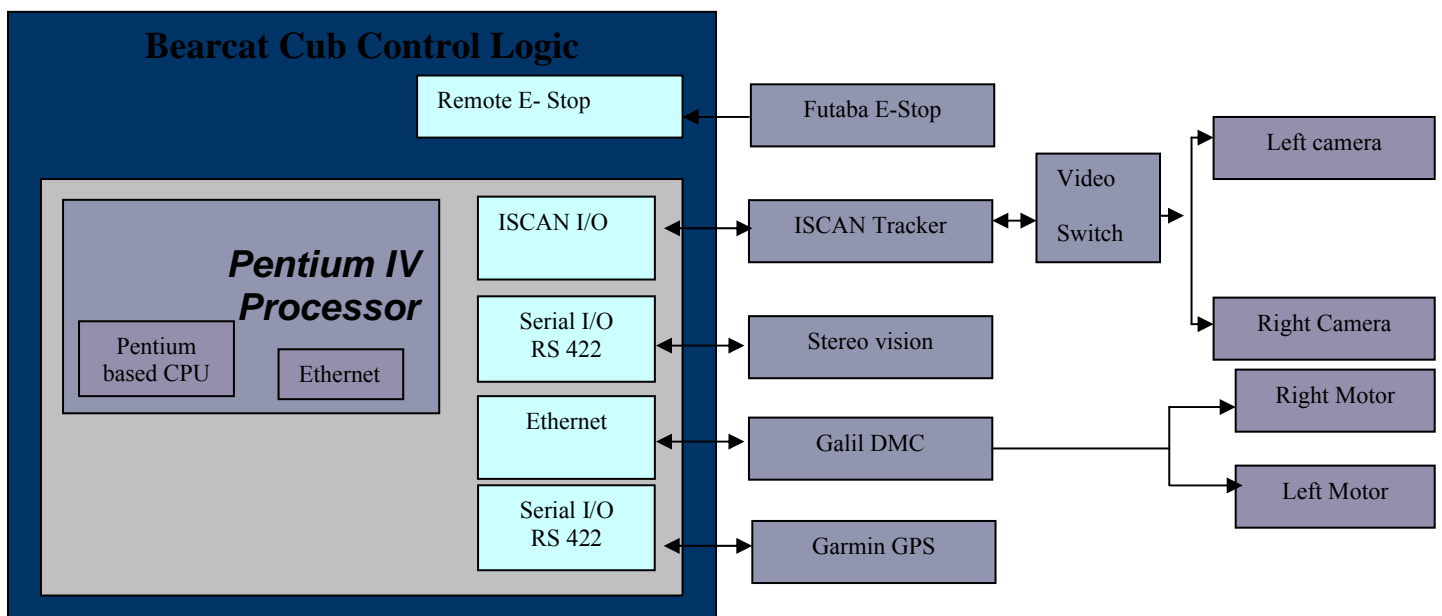

Figure 5. Bearcat Cub block diagram

4.1 DMC Motion Controller

The Galil DMC 2130 motion control board is the main controller card of the system and it is controlled through a computer. Coply amplifiers deliver power to the motors after amplifying the signals they receive from the motion controller. Steering is achieved by applying differential speeds at the right and left wheels. The obstacle avoidance system sends data to the computer which is also used to determine the change in performance of the motors. The Galil motion controller is the one used on the Bearcat Cub. It is compact and is enclosed in a durable container. The controller can accommodate 1-8 axis formats and can control stepper or servomotors on any combination of axes. The motion control of the Bearcat Cub has the ability to turn about its drive axis which is called Zero Turning Radius (ZTR). The block diagram of the system is shown in Figure 6.

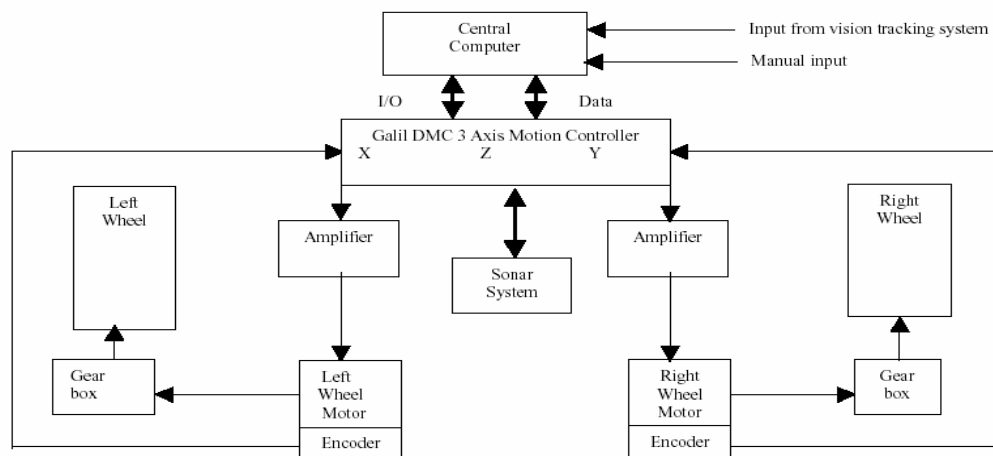

Figure 6. Motion control system

4.2 Vision Systems

The cameras provide the image that is used by the line following and obstacle avoidance systems. The cameras used by the cub are Sony handy cams. Each camera has its own LCD monitor. There are 2 cameras, the right and left cameras, for line following. The two outside cameras use a video switch which takes inputs from both the cameras but uses the output from only one of them at a time. The switch helps to use the output from the other camera if the first one loses sight of the line. An imaging board is also present which has software having the capability to detect the white part of the line and move accordingly. The video tracker works in conjunction with the computer program to detect

the obstacle, find the centre portion of the obstacle, and then take the necessary steps to avoid it by following the instructions from the computer based on the program.

4.3 Bumblebee Stereo Vision

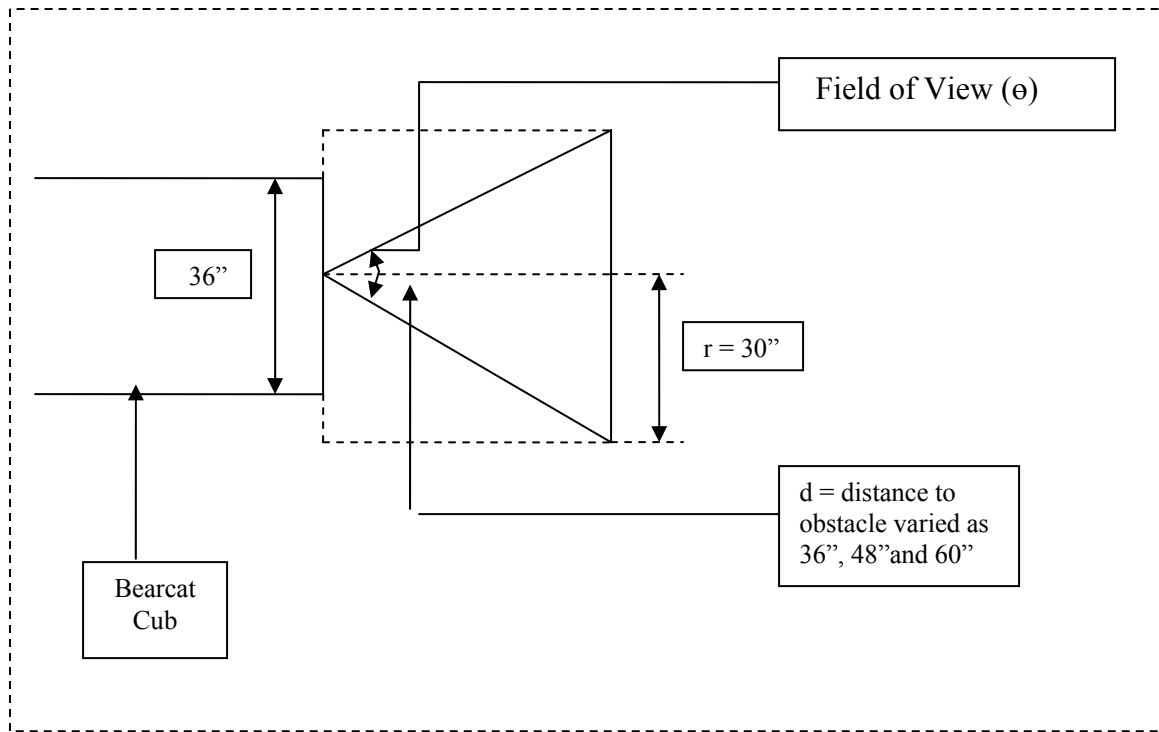

Figure 7. Stereo vision system

Field of view is the width, height or diameter of a scene to be monitored. It is usually determined by the focal length of a lens and the distance to the objects. In the figure above, 'θ' is considered as the field of view. 'd' is the distance between the robot and the obstacle. The width of the robot has been measured and the value obtained is 36 inches. A distance of 12 inches beyond the robot on either side is assumed to be within the field of vision. Thus, in this problem, the known values are:

$d = 36", 48", 60"$ (for varying distances between the robot and the obstacle).

$r =$ distance from the center point of the robot to a point 12 inches wide of the robot. This length is found to be 30" from measurements made.

Thus, $\theta/2$ can be found with the following simple equation.

$$\tan (\theta/2) = r/d = 30/36$$

$$\begin{aligned}(\theta/2) &= \tan^{-1}(0.8333) \\ &= 39.80\end{aligned}$$

The field of view $\theta = 79.6^\circ$

As the distance 'd' increases, the angle field of view decreases and so the field of view angle would be the highest for this case.

The Bumblebee stereo vision system comes with the choice of 3 different lenses- 2mm, 4mm, and 6mm. The field of view for these lenses is 100° , 70° , and 50° respectively.

The conclusion is that we need the vision system with 2mm lenses.

4.4 Emergency E-stop

The contest rules require that the robot consist of an emergency e-stop system that can work from a distance of 50 feet. The robot also has a manual emergency stop system but the e-stop is a remote control electrical device that can make the robot stop from a distance. The e-stop for the cub consists of a Futaba transmitter, a receiver, an amplifier and a solid state relay. The transmitter sends FM signals at a specified frequency. This signal activates the relay, which in turn, activates the emergency stop and cuts power to the motor. The advantage of using this transmitter is that it does not have to be in line of sight with the receiver for it to work.

4.5 Global Positioning System (GPS)

A commercially available GPS system has been used for the Bearcat Cub. The main criteria for the selection are Wide Area Augmentation System (WAAS) capability, and embedded navigation features. The Garmin 76 has the before mentioned requirements and has thus been selected for implementation. The GPS tracks the NAVSTAR GPS constellation of satellites. The signals are received by an antenna and are tracked with 12 parallel channels of L1. C/A code is then down converted to an IF frequency and digitally processed to obtain a full navigation solution of position, velocity, time and heading. The solution is then sent over the serial link via the 10-pin connector. This is shown in Figure 8.

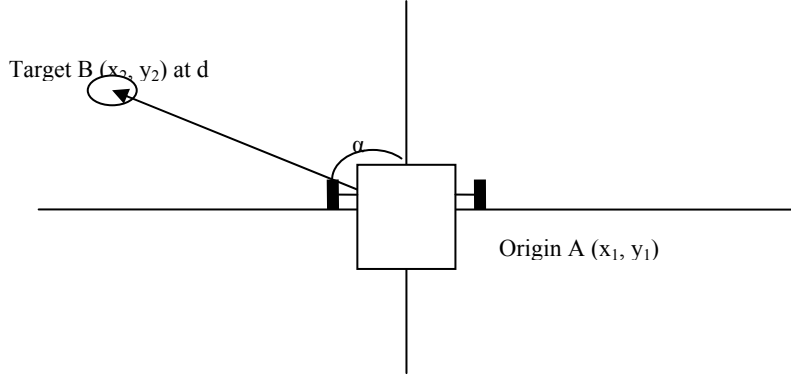

Figure 8. Point to point motion between waypoints

4.6 Servo Motors

Bearcat Cub uses DC Brushless servo motors PMA43R-00112-00 provided by Pacific Scientific. Servo motors are small and powerful and efficient for servo controls. The circuit board based on the feedback from encoder in the motor, gives signal to the amplifier. The amplified signal is sent to the motor to turn proportionately. The difference between the actual position and position reached is sensed by the encoder in the motor and fed back to the circuit board which modifies the signal by a PID compensator that is to be sent back to the amplifier. Thus, servo motors are useful in achieving minimal error and maximum accuracy. For stepper motors, no encoder is present as it sends signals only in steps.

5. Computer System

A laptop is the central processing unit of the Bearcat Cub. It processes data from stereo vision, the GPS system and Iscan system that control the cameras. As weight is one of the major considerations in Bearcat Cub design, a Pentium 4 laptop is used as the processor for the robot. The movement of the vehicle is determined by the software with inputs from different components. The program is written in C++ by using the Visual Studio .NET compiler.

5.1 Line Following

For the line following competition, the Bearcat Cub has been designed to negotiate an outdoor obstacle course in a prescribed time while staying within 5mph speed limit and avoiding obstacles. Inputs from both the cameras are fed in with the Iscan tracker processing the image of the line. With reference to the robot's orientation, the brightest spot is detected on the image, which is considered as the line to be followed.

As mentioned before, the vision system comprises of two cameras. The Iscan tracker, which processes the image of the line, finds the centroid of brightest or darkest captured image. At any time, Bearcat Cub tracks only one line. When the track is lost, the central controller switches control to the other camera. Calibration of the camera is done to determine the relationship between the real world 3D coordinate systems to 2D coordinate system, as perceived by the image of the camera. The centroid of the line segments for the two images obtained on the screen is returned to the Iscan tracker as shown as points (x_1, y_1) and (x_2, y_2) as shown in Figure 10. These points are used to determine the angle and distance between the robot and the line.

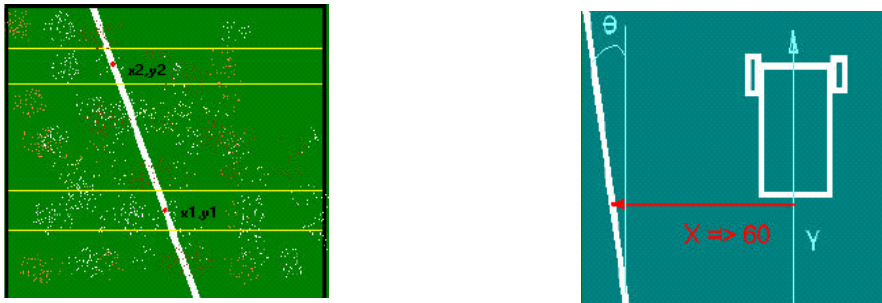

Figure 9. Line Following using two narrow windows

5.2 Obstacle Detection

A stereo vision system is placed in the front of the robot and is used to determine the presence of any object in front of the vehicle. The range of the system was chosen to be eight meters with 1^0 resolutions for the contest. The frontal area of the robot is divided into 4 zones as shown in Figure 10. The following algorithm is used to check for the presence of obstacles in each zone, and then adjust the robot's path.

Every time the program gets a feedback from the stereo vision, a variable called *ob_factor* is initialized to zero and updated according to the following pseudo-code:

```

for (each zone, i = 1 to 4)
{
    if (obstacle is present in zone)
    {
        ob_factor = (ob_factor*10) + i
    }
}

```

If there are no obstacles in the path, the variable *ob_factor* remains zero. If there are any obstacles, the variable accordingly provides information on the configuration of the obstacles.

While checking for the presence of obstacle in each zone, if there is an obstacle present, the program also records three values, *ob_left*, *ob_right*, and *ob_near*. For each zone, the program sweeps the data array received from the stereo vision from the starting angle of the zone to the ending angle of the zone and checks for the presence of obstacle within the radial dimension shown in Figure 10.

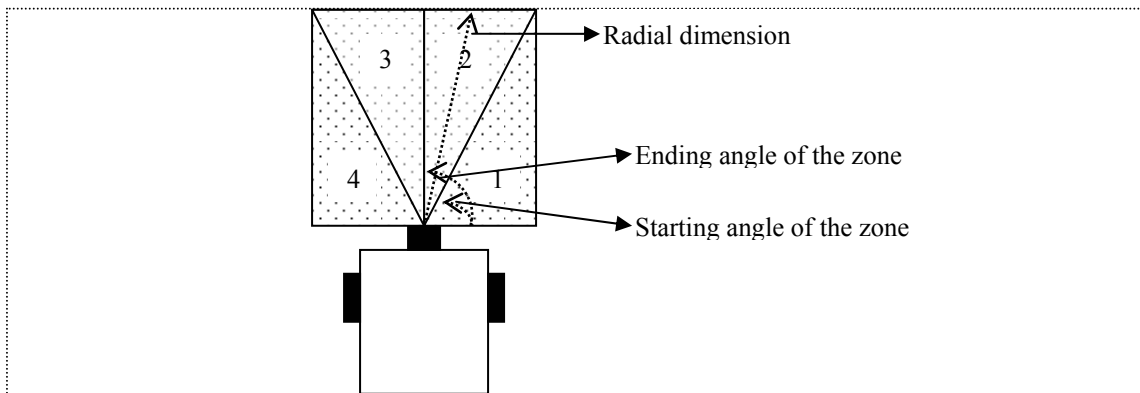

Figure 10. Zones, angles and radial dimensions

If the distance measured is less than that of the radial dimension of the zone, it indicates the presence of an obstacle. The two values *ob_left* and *ob_right* are recorded to indicate the angular points where the obstacle is present in the left and right extremes of the zone respectively. The value *ob_near* indicates the angular point where the obstacle is closest to the robot. The corresponding distances of the obstacle for the three angular points are also recorded for each zone. After processing the boundaries are reduced as shown in Figure 12.

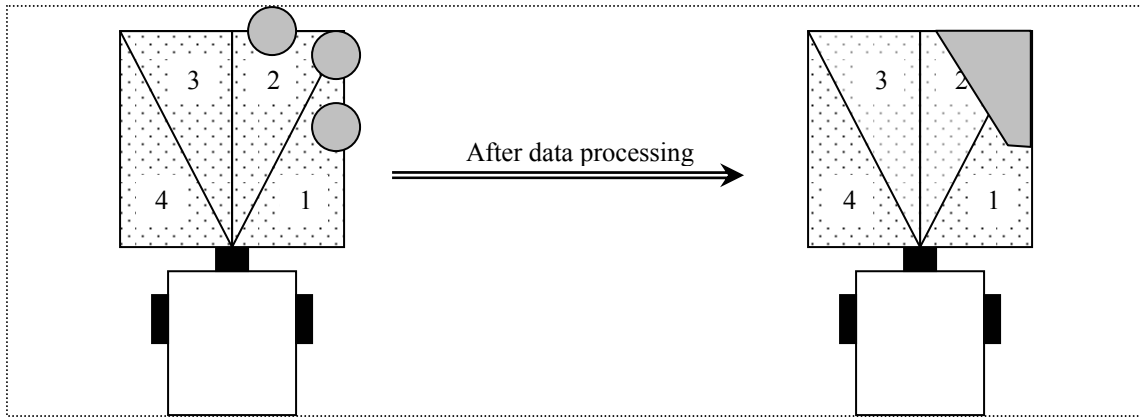

Figure 12. The obstacles as seen by the program after data processing

5.2 Way Point Navigation

Global Positioning System (GPS) technology lays the basis for way point navigation in the Bearcat cub. The classical closed feedback control loop was utilized in the modeling of the navigational challenge problem, with an input command, feedback signal, error signal, and output transfer function characteristics. The target waypoint destinations are specified as the input command and the feedback signal is provided by the Garmin GPS 76 based on its position with reference to satellite data. Using the current position coordinates, the GPS Garmin 76 provides bearing and range from the target waypoint to determine the error. Correction signals are generated to reduce the error to a certain tolerance based on the bearing angle error signal generated by the Garmin GPS 76 unit. The corrective signals are sent to the robot motion control system, which translates the commands into motor control voltages that steer and propel (right, left or stop) the robot on the course. Once the bearing angle error and target range have been reduced to the required tolerance, the robot reaches its target destination waypoint. Now, the process continues for all the waypoints in the input file finally returning the robot to the home base. Since the navigational challenge also has obstacles, the Bearcat Cub with the aid of Point Grey stereo vision system, performs obstacle avoidance during waypoint navigation. The navigational program routine is transferred to stereo the vision's control in the event of an obstacle in the range. Once the robot effectively evades the obstacles, the original target waypoint is restored and the navigational routine is resumed.

6. System Integration

This is the portion where all the individual sub systems have to work in a cohesive fashion and make the robot work to meet the expectations. The line following algorithm makes sure that the robot is within the course. The front camera sends the image it sees to the computer and again a specified sub routine determines the presence of simulated potholes. The stereo vision detects the presence of obstacles and obstacle avoidance takes precedence over pothole detection. Whenever there is a need to change the direction of motion, the computer sends signals to the motion controller which in turn makes the motors and wheels work accordingly. The frame of the robot supports all the individual parts and also provides protection from collisions.

7. Safety and Reliability

There are three different safety systems built in to stop the robot. One is the manual e-stop system and another is the remote control e-stop system capable of stopping the robot from a range of 65 feet, which is higher than the contest requirements of 50 feet. A third safety is provided by a power disconnect switch. The gearboxes have also been selected to stop when power is not applied. The motor generator sets selected have hazards from both internal combustion and electric powered systems. However, properly used, the risks are the same as for other small engine devices.

Reliability of a new robot is difficult to predict. A potential failure mode and effects analysis will be done during testing. Front bumpers are present which reduce the impact of physical shocks from reaching the stereo vision and cameras mounted on the robot. All circuits have been color coded to ensure proper reconnection with the black for ground.

8. Performance

The performance for key requirement is shown in Table 1.

	Task	Requirement	Measured
1	Line following	Solid and dashed lines, white or colored, left or right	Accuracy 0.3 inch
2	Obstacle avoidance	Detect and turn	Detect and turn
3	Pothole detection	2 foot diameter	2 foot diameter
4	Waypoint detection	5 foot radius	5 foot radius
5	Emergency stop	50 foot range	65 foot range
6	Turning radius		0 degrees
7	Maximum speed	5 mph	5 mph
8	Ramp climbing ability	15 degrees	20 degrees
9	Braking distance	6 feet	1 foot

Table 1. Comparison of requirements and measured performance.

9. Conclusion

The robot has been assembled and tested and it has matched our expectations. The robot hardware cost \$23,135 and a bill of materials is shown in Appendix 1. This cost does not include travel costs or the cost of 480 man hours spent designing and building the robot.

Acknowledgement

The team is grateful to the industry sponsors: ROV Technologies, P&G, GEAE, Krogers, SME, Mr. Jims; University sponsors: SOA, GSGA, MINE Department; and individual sponsors: Dr. Joseph H. Nurre, Mr. John J. Judge, Dr. Richard L. Shell, Dr. Ronald Huston, Mr. Ronald Tarvin, Mr. Jin Cao, Mr. Dinesh Kumar Dhamodarasamy, Dr. Eugene Merchant, Mr. Ed Barnes, Mr. Hank Deardurff and Mr. John Clock and many individuals for their efforts in making this robot design and building process a success. We ate a lot of pizza, made friends and remembered to have fun. Our motto is adapt, improvise and overcome.

References

1. Ka C. Cheok, Ernest Hall, David Ahlgren, William Agnew, and Gerald R. Lane, "The Intelligent Ground Vehicle Competition (IGVC): A Cutting-Edge Engineering Team Experience," **Proceeding of the ASEE Annual Conference**, 2003, Nashville, TN.
2. Nick Gartner and Scott Bailey, "Bearcat Cub UC Design Clinic Report,' June 2002.
3. Masoud Ghaffari, et. al., "Design of an Unmanned Ground Vehicle, Bearcat III, Theory and Practice, "
Journal of Robotic Systems, Special Issue on the IGVC, Wiley, 2004.

CERTIFICATION

I certify that the engineering design in the vehicle Bearcat III (original and changes) by the current student team identified in this Design Report has been significant and equivalent to what might be awarded credit in a senior design course.

Ernest L. Hall, Paul E. Geier Professor _____
Faculty Advisor to the UC Robot Team

APPENDIX

Part	Manufacturer	Model No	Price
Frame	80/20 Inc.	Custom design	\$1,100
Generator	Honda	EU 2000i	\$778.00*2=\$1556
Motors	Pacific scientific	PMA43R-00112-00	\$970.00*2=\$1940
Amplifiers	Copley Controls Corp.	Xenus Servo Drives XSL-230-36	\$768.00*2=\$1536
Drive Wheels	Segway	Enhanced Traction	\$188*2=\$376
Gearboxes	Segway gear box ratio 25/1	HT design	\$688*2=\$1376
Castor wheel	Borne	8 inch, 90 series, castor wheels	\$100
Laptop & accessories	Dell	Pentium 4 at 2.20GHz with 512K L2 Cache Hard drive: 60GB4 Ultra ATA/100 7200RPM Hard Drive Memory: 512MB DDR SDRAM	\$2,500
I Scan	Iscan Inc.	RK-446BMP	\$3,200
Camera switcher	FSR Inc.	CCSU-8 BW	\$1,541.00 Donated
Cameras	Sony	PV-DV51	\$419*2=\$838
E-stop	Futaba	FRF-0302U	\$321
Motion controller	Galil Inc.	DMC-2130 web based	\$3,900
Camera mounts	Pelco	PS7-24,PT270P	\$300
GPS	Garmin	Garmin 76	\$251
Stereo vision	Pointgray	Bumblebee	\$2,000
Cover	Plexiglas	Stark Plastics	\$300
TOTAL			\$24,135